



FTD

Caratteristiche: diffusore a pavimento con effetto elicoidale.

Costruzione: alluminio pressofuso e sbavato. Cestello raccogli-polvere e elicoide di regolazione in acciaio zincato.

Impiego: su pavimento galleggiante, in mandata.

Fissaggio: mediante piastra di fissaggio e viti per pavimenti spessi fino a 50 mm.

Characteristics: floor twist diffuser.

Finishing: die-cast and deburred aluminium. Dirt trap and adjustable swirl element are made of galvanized steel.

Utilization: for false floor installation and for air delivery.

Fixing: by fixing plate and screws for false floors with thickness less than 50 mm.

DISEGNI | DRAWINGS

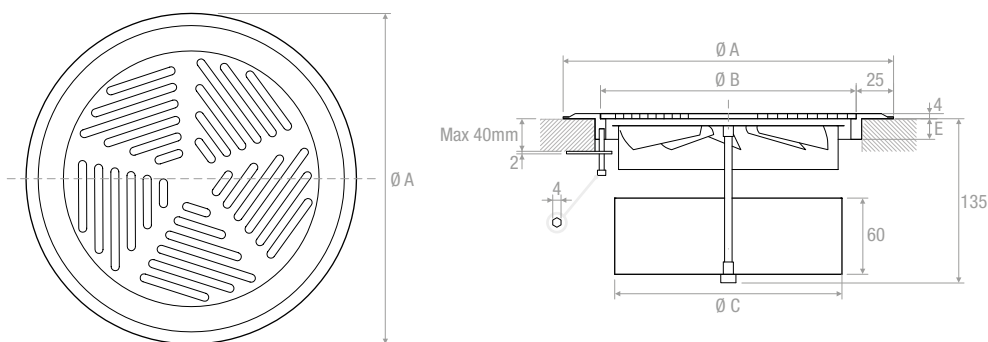

	Ø A	Ø B	Ø C	E
mm	mm	mm	mm	mm
150	190	140	126	14
200	240	190	176	19

TABELLA DI SELEZIONE | TECHNICAL DATA

Modello - Model	A _x [m ²]	Q [m ³ /h]		L _{WA} [dB(A)]		X _(0,25) [m]		D _{p1} [Pa]	
		min	max	min	max	min	max	min	max
FTD150	0,00446	40	80	41	58	0,47	0,72	10	50
FTD200	0,01600	50	100	34	50	0,38	0,55	10	50

VERSIONI DISPONIBILI | VERSIONS AVAILABLE

stock

mm	
150	
200	