



CARATTERISTICHE:

I ventilatori in linea da canale CKM sono progettati e costruiti per un inserimento rapido e sicuro nei tratti di condotto rettangolare.

I ventilatori sono provvisti di girante in acciaio zincato a semplice aspirazione con motore elettrico direttamente accoppiato raffreddato dal fluido convogliato. Le ventole sono alloggiare in una cassa in acciaio zincato provvista di flange per il fissaggio ai condotti.

Il gruppo ventilante è montato su di una portello a battente in grado di assicurare una manutenzione rapida e la completa sanificabilità del ventilatore.

CHARACTERISTICS:

In-line duct fans CKM are designed and built for rapid and secure insertion in rectangular ducts. The fans are equipped with galvanized steel impeller single inlet with motor connected directly cooled by air flow. The fans are housed in a box made of galvanized steel with flange for fixing to the ducts.

The motorized impeller is mounted on a hinged door that ensure easy maintenance and complete sanitization of the fan.

TABELLA TECNICA DATI GENERALI - PREZZI - GENERAL TECHNICAL DATA TABLE - PRICES

■ STOCK

MODELLO MODEL	TENSIONE - VOLTAGE	FREQUENZA FREQUENCY	POTENZA - POWER	CLASSE ISOLAMENTO INSULATION CLASS	CORRENTE - CURRENT	REGOLATORE CONTROL	VELOCITÀ SPEED	€
	V	Hz	W	class	A		RPM	
CKM 30 - 15	230	50	90	IP 55	0,4	RC2A	2630	
CKM 40 - 20 A	230	50	104	IP 55	0,47	RC2A	2645	
CKM 40 - 20 B	230	50	130	IP 55	0,58	RC2A	2675	
CKM 50 - 25	230	50	180	IP 55	0,8	RC2A	2635	
CKM 60 - 30	230	50	147	IP 55	0,66	RC2A	1440	
CKM 60 - 35 A	230	50	340	IP 55	0,64	RC2A	1440	
CKM 60 - 35 B	230	50	380	IP 55	0,96	RC2A	1420	
CKM 70 - 40 A	230	50	620	IP 55	2,06	RC5A	1430	
CKM 70 - 40 B	230	50	690	IP 55	3	RC5A	1435	
CKM 80 - 50	400	50	1080	IP 55	2,5	-	1350	
CKM 100 - 50	400	50	1670	IP 55	3	-	1350	

MODELLO MODEL	€
RC2A	
RC5A	



DISEGNI - DRAWINGS



TABELLA DIMENSIONI - DIMENSIONAL TABLE

Modello - Model	A	B	C	D	E	F	G
CKM 30 - 15	150	300	400	320	170	350	200
CKM 40 - 20 A	200	400	500	420	220	450	250
CKM 40 - 20 B	200	400	500	420	220	450	250
CKM 50 - 25	250	500	565	520	270	550	300
CKM 60 - 30	300	600	650	620	320	650	350
CKM 60 - 35 A	350	600	760	620	370	650	400
CKM 60 - 35 B	350	600	760	620	370	650	400
CKM 70 - 40 A	400	700	800	720	420	750	450
CKM 70 - 40 B	400	700	800	720	420	750	450
CKM 80 - 50	500	800	920	820	520	850	560
CKM 100 - 50	500	1000	1050	1030	530	1060	560

TABELLA PRESTAZIONI - PERFORMANCE TABLE

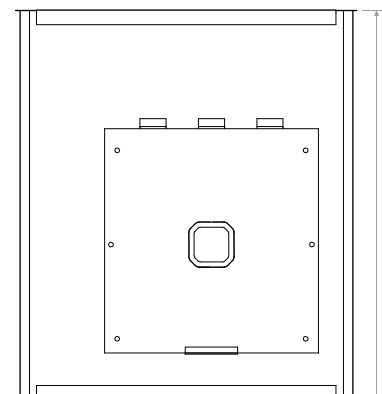
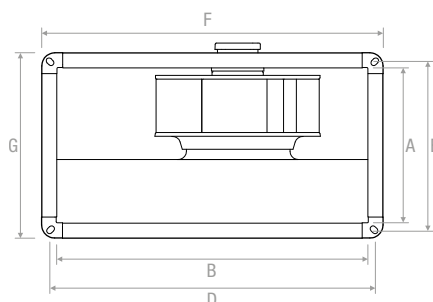
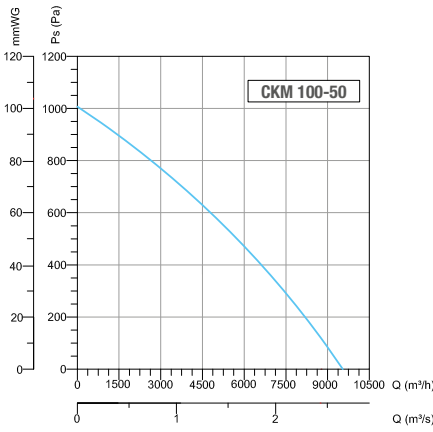
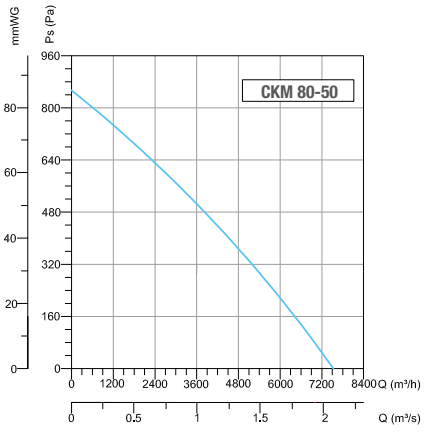
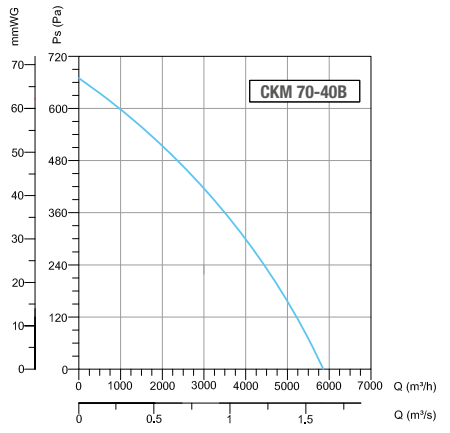
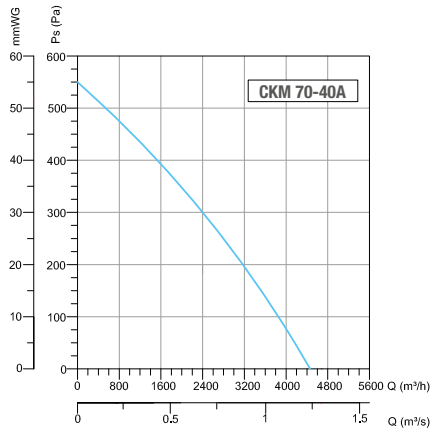
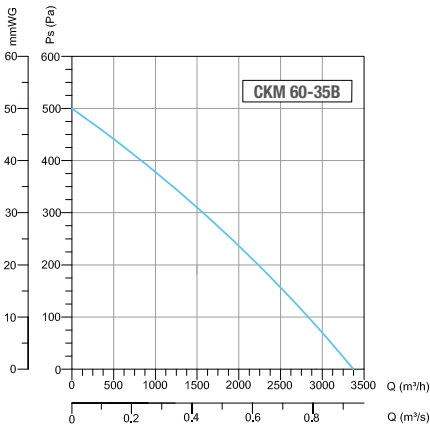
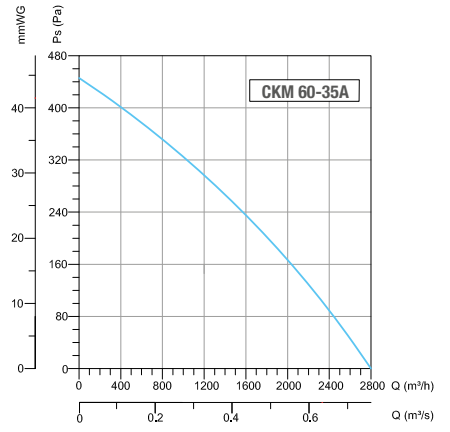
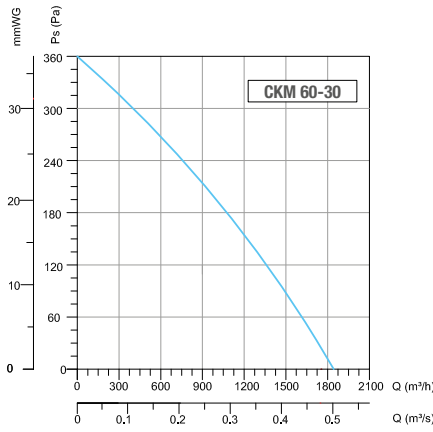
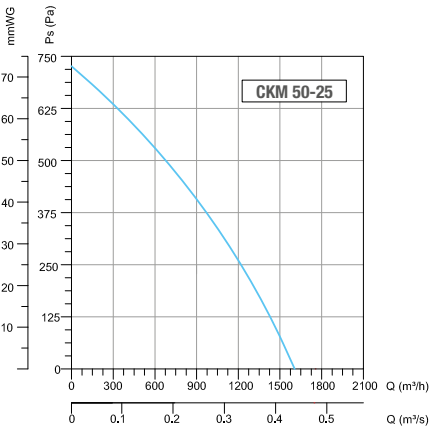
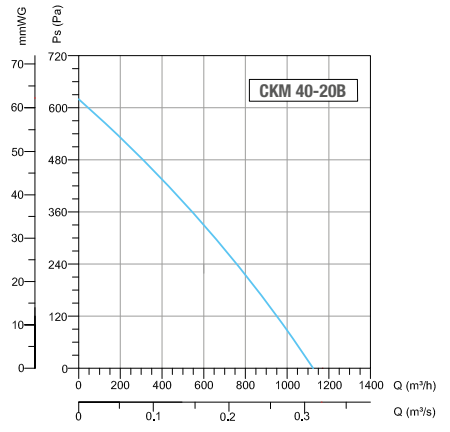
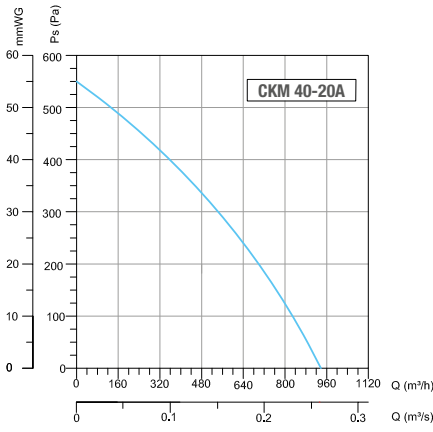
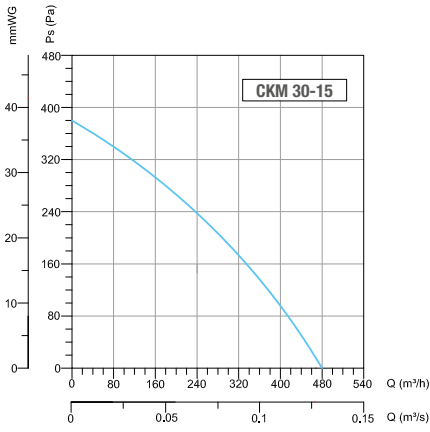

VEN